

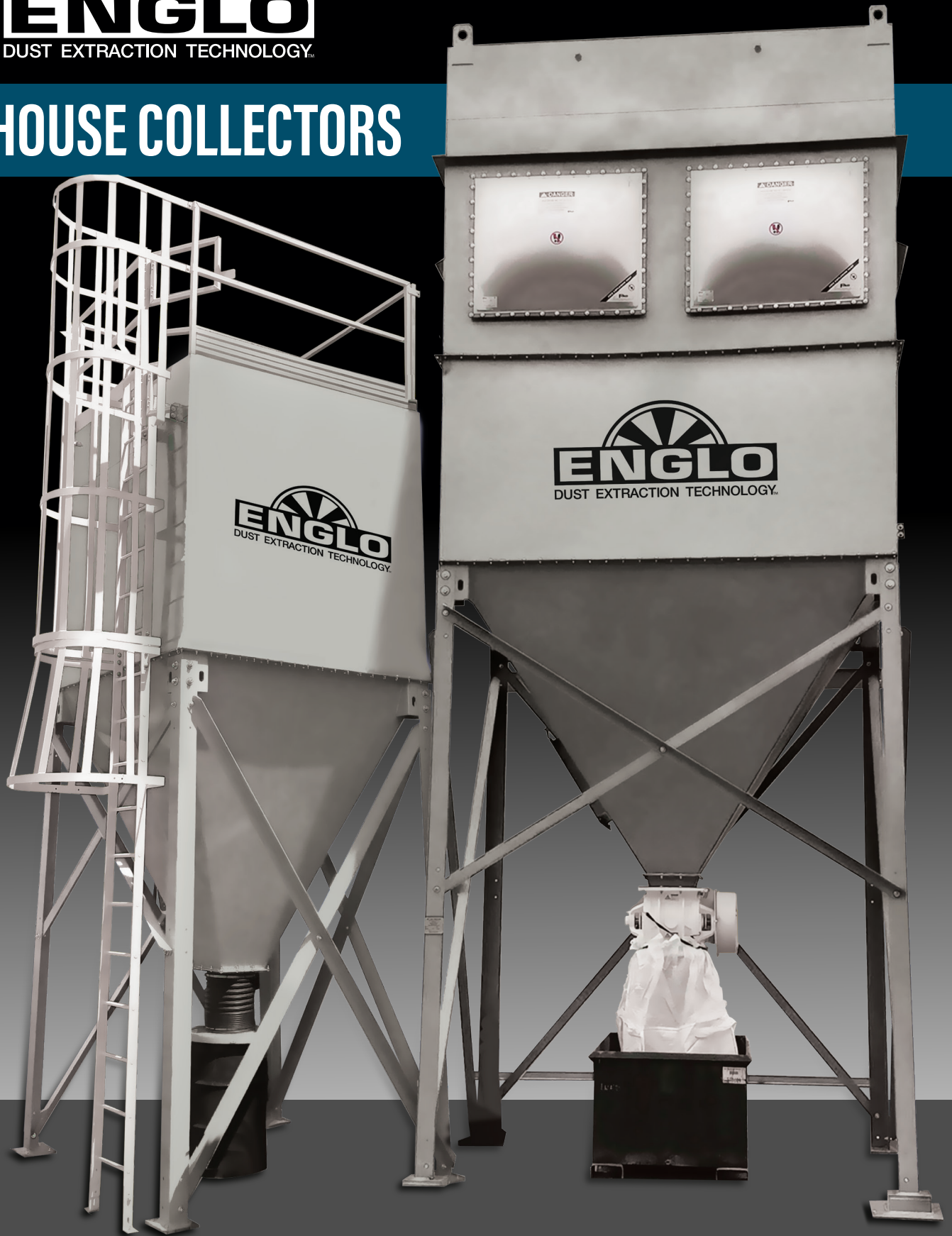

BAGHOUSE COLLECTORS





EXPERIENCED SERVICE & SUPPORT

- Technical expertise and factory support
- Ready-to-ship parts and filters
- Numerous successful installations worldwide

CUSTOM ENGINEERING

- Systems tailored to your specific needs
- Professional design & engineering experts
- Application assistance

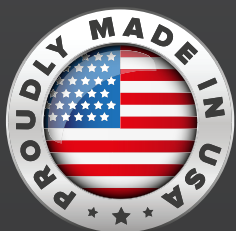

BAGHOUSE FEATURES

- Modular Design
- Venturi-Assisted Pulse-Jet Cleaning
- Automatic Pulse Controls for both Online and Downtime Cleaning
- Action-Lock Exclusive Tool-Free Bag Replacement
- Clean Side, Top Access Snap Band Filter Bags
- Top Load Filter Change Out
- Hinged Filter Access Doors
- No Confined Space Filter Access
- OSHA Compliant Hand Rail and Caged Access Ladder
- Replaceable Bolt-On Deflection Baffle
- Pressure/Vacuum Rating $\pm 25''$ W.C.
- Premium Prime and Paint Exterior High Gloss Enamel
- 16 oz Polyester Filter Bags with Stainless Steel Snap Band



ENGLO Dust Collectors

TLM Modular Baghouse is designed to meet the unique requirements of each application.

Starting with transportation, the dimensions of the TLM Baghouse are such that trucking can be done without oversize permits. Installation is simple and straightforward with the modular design and integral lifting lugs. Overall design is compact to minimize footprint and overall height to fit in the tightest space available.

Heavy-duty internally reinforced 10-gauge walls and robust structure meet industry demands. Utilizing computerized simulation software, the pulse-jet cleaning system operational design has been optimized for efficient cleaning and airflow. Hinged filter access doors and our exclusive toolfree bag replacement, allow for the quickest, easiest maintenance.

The TLM Baghouse brings you the culmination of many years of experience with quality and features unrivaled in the industry.





As the dust accumulates on the filters, an on-board pressure gauge monitors differential pressure between the clean side and the dirty side of the baghouse.

Once a set maximum differential pressure is reached, a solid state timer board activates the cleaning system. The timer board activates an electric solenoid, which opens the diaphragm valve. Compressed air from the manifold on the baghouse is released through the diaphragm valve into the blowpipe above the bag filters. The pressure from the pulse-jet removes the dust buildup by blowing it off outward from the inside of the filter. This all occurs while the system is online for continuous duty operation.

The TLM Baghouse features downtime cleaning as well, so the system performs a final pulse-clean cycle after shutdown to ensure maximum dust release and long filter life.

AVAILABLE BAGHOUSE OPTIONS

Rotary Airlocks with Hopper Mount Transitions

Screw Conveyors

Extended/Modified Steel Support Structure

Custom Filter Media Options

Motor/Blower for Specific Performance

Inlet or Outlet Dampers

Exhaust Silencer

Ductwork and Inlet/Outlet Manifolds

Afterfilter Plenums for HEPA or ASHRAE

NFPA 69 Compliant Backdraft Dampers/
Explosion Isolation Valves

Explosion Venting

Motor Control Panels, (Soft Start, VFD's etc.)

Spark Detection System

High Speed Abort Gates

High Temperature Operation Components

Stainless Steel Construction

Custom Color Exterior Paint Finishes

Contact ACT for Additional Options

The most popular feature is our exclusive

ACTION LOCK, TOOL FREE BAG REPLACEMENT.

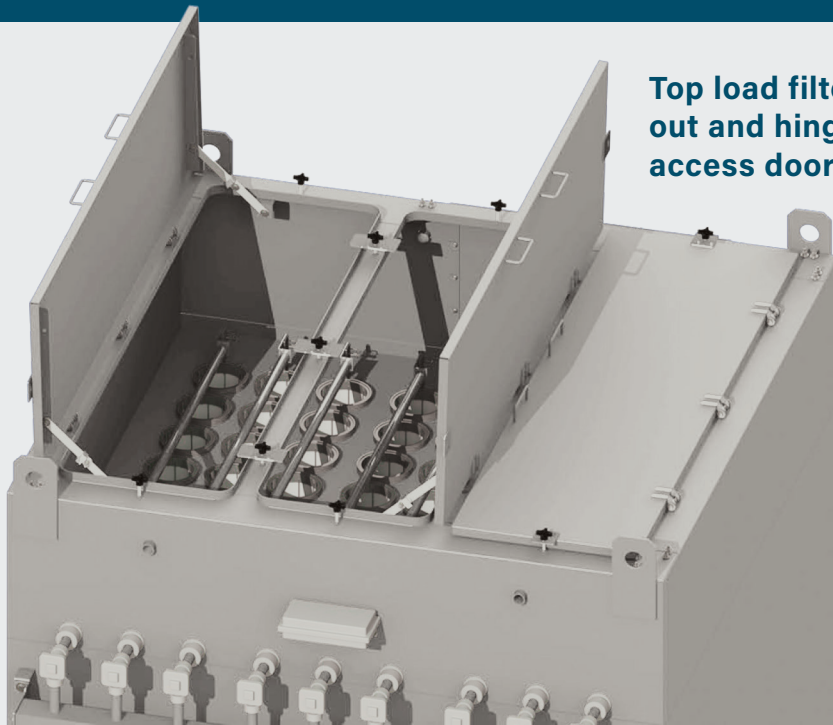

Top load filter change out and hinged filter access door.

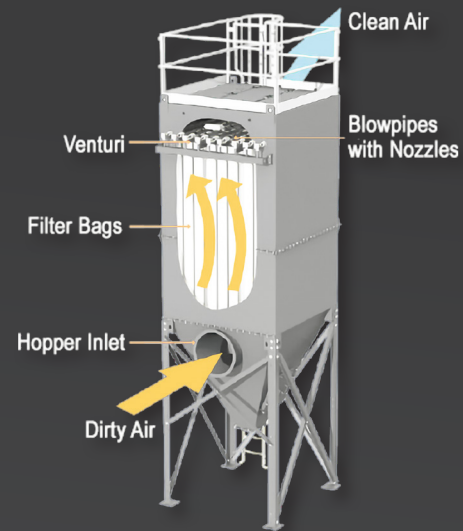

The TLM Baghouse operation is simple, proven, and efficient. Dust-laden air is drawn from the source through a duct system and into the hopper inlet.

1 Safety-lock, hinged filter access door

2 Swing-away, hinged pulse tube

3 Drop in cage and snap-band filter bag

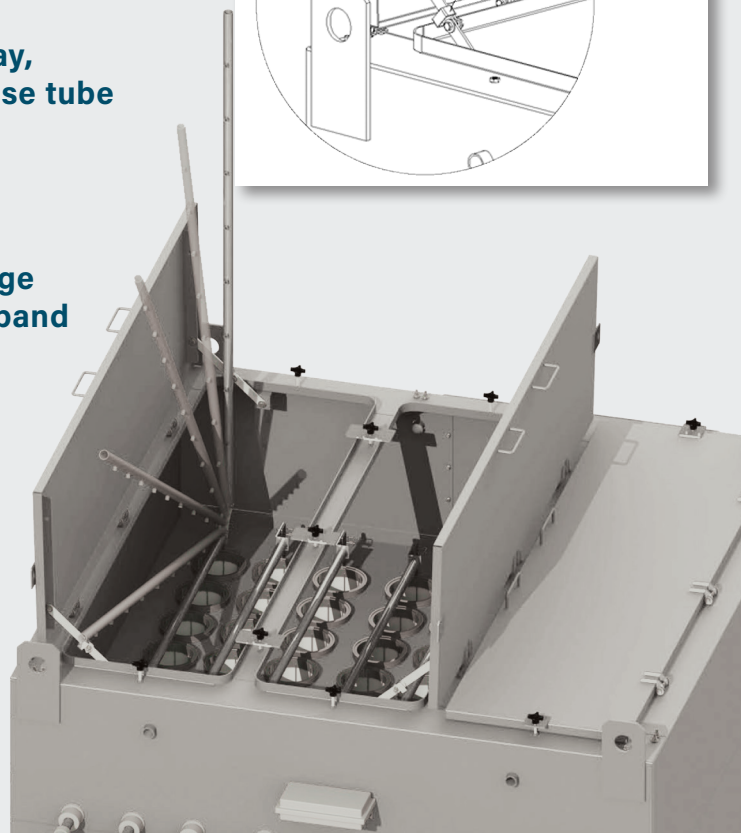
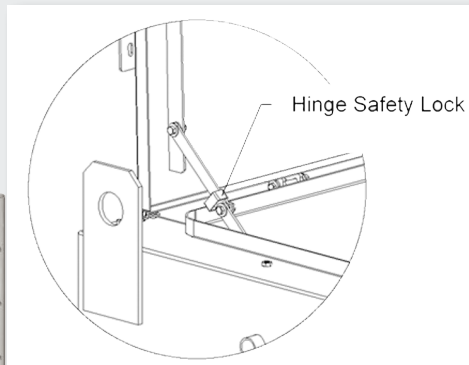

Through air expansion and an internal deflection plate, the airstream velocity is reduced so large particles drop into the hopper below. The remaining dust particles are filtered through bag filters.

This ensures that only clean air passes into the clean air plenum, through the fan, and is either exhausted to the atmosphere or returned to the building.

DIMENSIONS

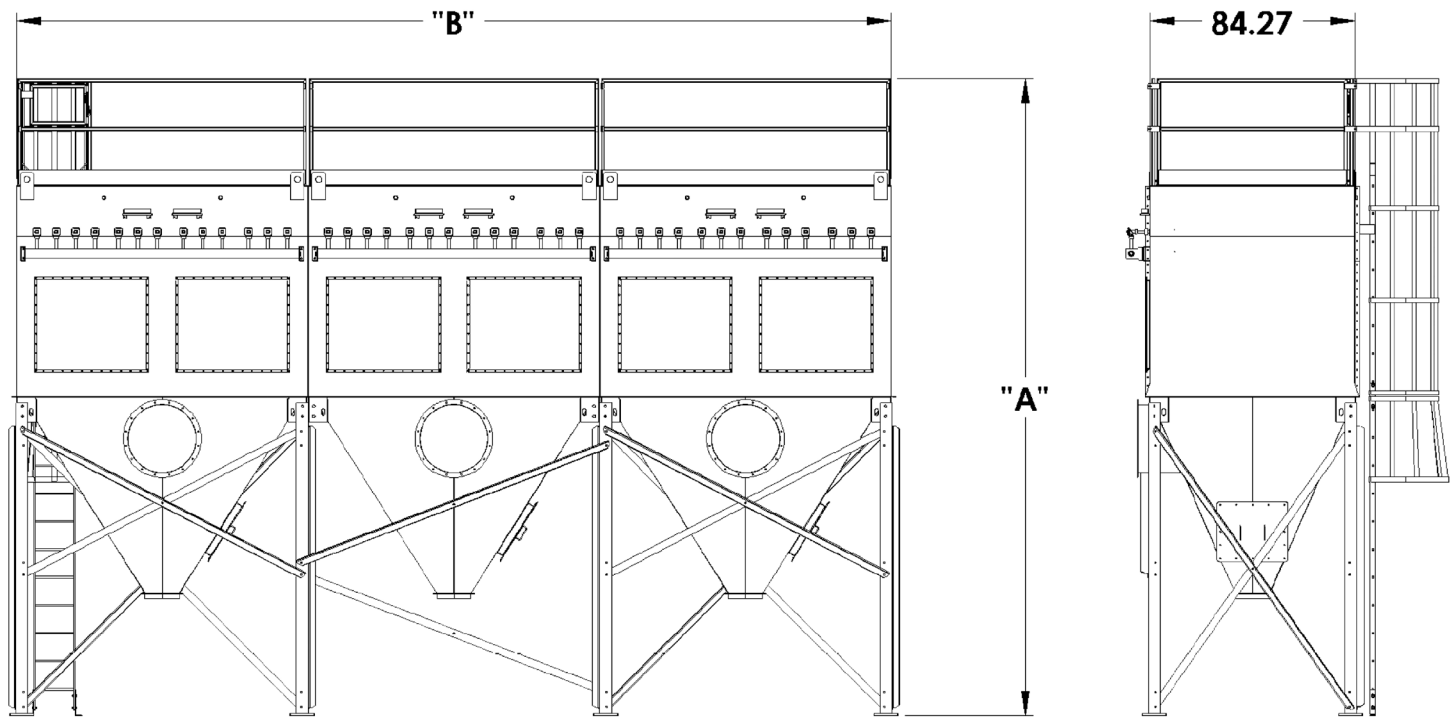

TLM 5FT MODULES

MODEL	NOMINAL AIRFLOW RANGE (CFM)	FILTER MEDIA (FT ²)	# OF TLM 81 MODULES	# OF TLM 117 MODULES	# OF BAGS	# OF VALVES	BAG LENGTH (FT)	BAG DIAMETER (IN)	ESTIMATED SHIPPING WEIGHT (LBS)	DIMENSIONS	
										A	B
TLM 81-5	2,000-6,000	636	1	0	81	9	5	6	5,100	237.21	85.02
TLM 117-5	3,000-9,000	919	0	1	117	13	5	6	6,100	261.96	117.02
TLM 162-5	5,000-12,000	1,272	2	0	162	18	5	6	8,600	237.21	165.38
TLM 198-5	6,000-15,000	1,555	1	1	198	22	5	6	9,600	261.96	197.38
TLM 234-5	7,000-18,000	1,838	0	2	234	26	5	6	10,500	261.96	229.38
TLM 279-5	8,000-21,000	2,191	2	1	279	31	5	6	13,200	261.96	277.74
TLM 315-5	9,000-24,000	2,474	1	2	315	35	5	6	14,100	261.96	309.74
TLM 351-5	11,000-27,000	2,757	0	3	351	39	5	6	15,100	261.96	341.74
TLM 396-5	12,000-31,000	3,110	2	2	396	44	5	6	17,600	261.96	390.09
TLM 432-5	13,000-34,000	3,393	1	3	432	48	5	6	18,600	261.96	422.09
TLM 468-5	14,000-36,000	3,676	0	4	468	52	5	6	19,500	261.96	454.09
TLM 513-5	16,000-40,000	4,029	2	3	513	57	5	6	22,220	261.96	502.45
TLM 549-5	17,000-43,000	4,312	1	4	549	61	5	6	23,100	261.96	534.45
TLM 585-5	18,000-46,000	4,595	0	5	585	65	5	6	24,100	261.96	566.45
TLM 630-5	19,000-50,000	4,948	2	4	630	70	5	6	26,500	261.96	614.81
TLM 666-5	21,000-52,000	5,231	1	5	666	74	5	6	27,500	261.96	646.81
TLM 702-5	22,000-55,000	5,513	0	6	702	78	5	6	28,400	261.96	678.81
TLM 756-5	23,000-59,000	5,938	5	3	756	84	5	6	32,800	261.96	743.53
TLM 792-5	24,000-62,000	6,220	4	4	792	88	5	6	33,800	261.96	775.53

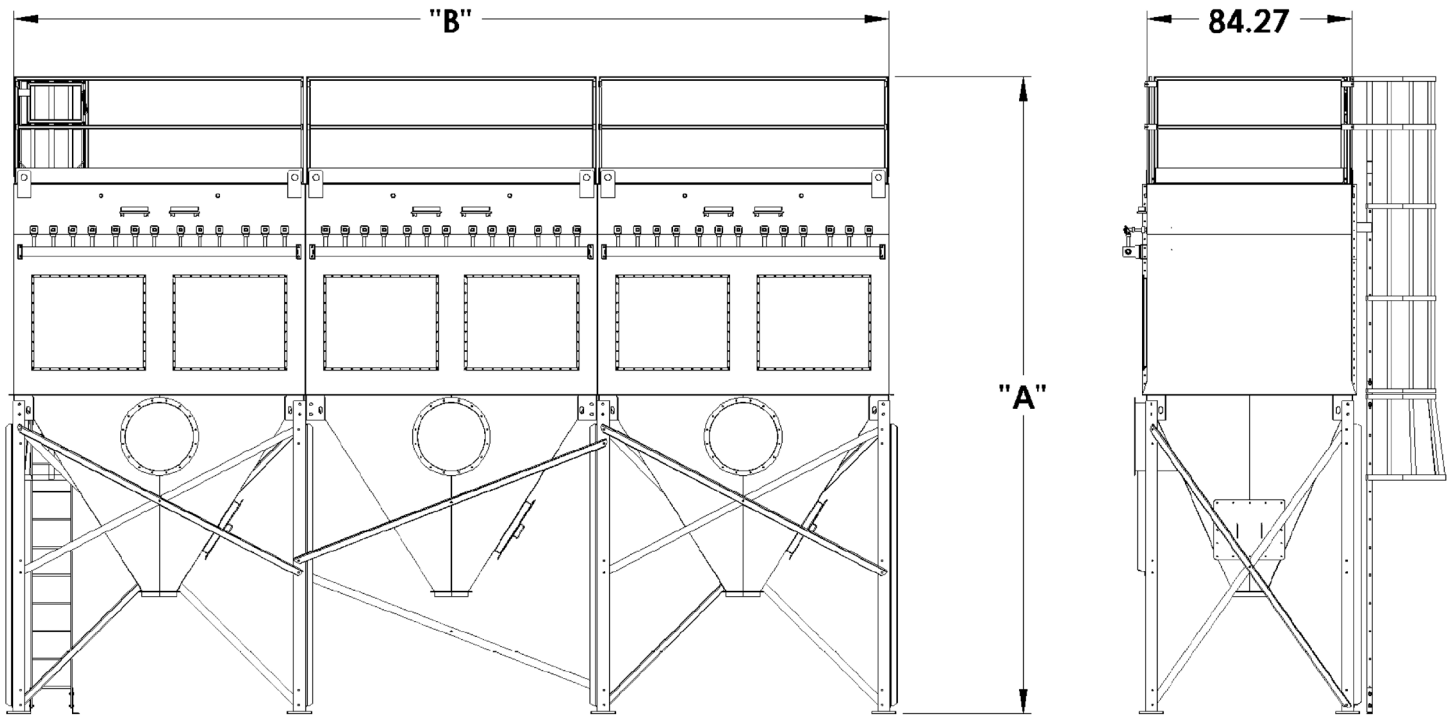

TLM 10FT MODULES

MODEL	NOMINAL AIRFLOW RANGE (CFM)	FILTER MEDIA (FT ²)	# OF TLM 81 MODULES	# OF TLM 117 MODULES	# OF BAGS	# OF VALVES	BAG LENGTH (FT)	BAG DIAMETER (IN)	ESTIMATED SHIPPING WEIGHT (LBS)	DIMENSIONS	
										A	B
TLM 81-10	5,000-12,000	1,272	1	0	81	9	10	6	6,000	297.21	85.02
TLM 117-10	7,000-18,000	1,838	0	1	117	13	10	6	7,100	321.96	117.02
TLM 162-10	10,000-25,000	2,545	2	0	162	18	10	6	10,100	297.21	165.38
TLM 198-10	12,000-31,000	3,110	1	1	198	22	10	6	11,200	321.96	197.38
TLM 234-10	14,000-36,000	3,676	0	2	234	26	10	6	12,400	321.96	229.38
TLM 279-10	17,000-43,000	4,383	2	1	279	31	10	6	15,500	321.96	277.74
TLM 315-10	19,000-50,000	4,948	1	2	315	35	10	6	16,600	321.96	309.74
TLM 351-10	22,000-55,000	5,513	0	3	351	39	10	6	17,700	321.96	341.74
TLM 396-10	24,000-62,000	6,220	2	2	396	44	10	6	20,700	321.96	390.09
TLM 432-10	27,000-67,000	6,786	1	3	432	48	10	6	21,800	321.96	422.09
TLM 468-10	29,000-73,000	7,351	0	4	468	52	10	6	23,000	321.96	454.09
TLM 513-10	32,000-80,000	8,058	2	3	513	57	10	6	26,120	321.96	502.45
TLM 549-10	34,000-86,000	8,624	1	4	549	61	10	6	27,200	321.96	534.45
TLM 585-10	36,000-91,000	9,189	0	5	585	65	10	6	28,300	321.96	566.45
TLM 630-10	39,000-98,000	9,896	2	4	630	70	10	6	21,200	321.96	614.81
TLM 666-10	41,000-104,000	10,462	1	5	666	74	10	6	32,300	321.96	646.81
TLM 702-10	44,000-110,000	11,027	0	6	702	78	10	6	33,500	321.96	678.81
TLM 756-10	47,000-118,000	11,875	5	3	756	84	10	6	38,500	321.96	743.53
TLM 792-10	49,000-124,000	12,441	4	4	792	88	10	6	39,700	321.96	775.53

DESIGNED, ENGINEERED, & MANUFACTURED IN USA



194 Shott Court
Bluefield, WV 24701

p: 304-253-0777

f: 304-253-0719

sales@engloinc.com

engloinc.com